

Plot Date: 6/26/2023 9:08 AM - File Name: 233464-Dankenbring\_svf\_Survey.dwg - If the surveyor's signature is not blue in color, the drawing is a copy that should be assumed to contain unauthorized alterations. The certification contained on this document shall not apply to any copies.

**TRACT 1 DESCRIPTION:**

A tract of land in the North Half of the Southwest Quarter (N 1/2 of the SW 1/4) and the Northwest Quarter (NW 1/4) of Section 16, the West Half of the Southwest Quarter (W 1/2 of the SW 1/4) of Section 9 and the East Half (E 1/2) of Section 8, all in Township 1 South, Range 4 East, of the 6th P.M., in Washington County, Kansas, prepared by Clint J. Friedrichs, PLS #1709 on June 21, 2023, being more particularly described as follows:  
BEGINNING at the Southeast (SE) corner of the NW 1/4 of said Section 16;  
THENCE North 89°05'09" West along the south line of the Northwest Quarter (NW 1/4) of said Section 16 for a distance of 659.75 feet to the corner of a tract referred to as "Outlot 9";  
THENCE North 01°19'33" West along the boundary of said "Outlot 9" for a distance of 528.00 feet;  
THENCE South 79°24'25" West along the boundary of said "Outlot 9" for a distance of 660.00 feet to the east line of the Northwest Quarter (NW 1/4) of the NW 1/4 of said Section 16;  
THENCE North 00°09'08" West along the east line of the NW 1/4 of the NW 1/4 of said Section 16 for a distance of 772.99 feet to the south line of the north 10 rods of the Southeast Quarter (SE 1/4) of the NW 1/4 of said Section 16;  
THENCE South 89°56'18" East along the south south line of the north 10 rods of the SE 1/4 of the NW 1/4 of said Section 16 for a distance of 623.82 feet to the west Railroad Right-of-Way (R/W) line;  
THENCE along said west Railroad R/W line for the following three (3) courses:  
THENCE North 28°42'32" West for a distance of 4036.32 feet;  
THENCE along a spiral curve to the left for 433 feet to a point 221.67 feet south and 182.98 feet west of the Northeast (NE) corner of the Southeast Quarter (SE 1/4) of said Section 8;  
THENCE North 32°10'47" West for a distance of 264.23 feet to the north line of the SE 1/4 of said Section 8;  
THENCE North 89°12'14" West along the north line of the SE 1/4 of said Section 8 for a distance of 104.35 feet;  
THENCE North 03°30'05" West for a distance of 173.49 feet to the south R/W line of Hollenberg Avenue;  
THENCE along the south R/W line of said Hollenberg Avenue for the following two (2) courses:  
THENCE North 89°46'32" West for a distance of 501.02 feet;  
THENCE South 86°48'35" West for a distance of 1193.89 feet;  
THENCE South 00°47'46" West for a distance of 85.00 feet to the north line of the SE 1/4 of said Section 8;  
THENCE South 89°12'14" East along the north line of the SE 1/4 of said Section 8 for a distance of 129.41 feet;  
THENCE South 57°39'16" East for a distance of 653.40 feet;  
THENCE South 34°14'37" East for a distance of 211.07 feet;  
THENCE South 38°00'44" East for a distance of 1150.00 feet to the centerline of the Little Blue River;  
THENCE along the centerline of said Little Blue River for the following twenty seven (27) courses:  
THENCE North 89°13'45" East for a distance of 235.00 feet;  
THENCE North 80°32'11" East for a distance of 175.00 feet;  
THENCE South 80°13'33" East for a distance of 228.00 feet;  
THENCE South 66°33'13" East for a distance of 465.00 feet;  
THENCE South 47°26'31" East for a distance of 200.00 feet;  
THENCE South 25°20'26" East for a distance of 500.00 feet;  
THENCE South 11°08'57" West for a distance of 112.00 feet;  
THENCE South 49°04'31" West for a distance of 160.00 feet;  
THENCE South 37°11'31" West for a distance of 450.00 feet;  
THENCE South 46°37'52" West for a distance of 378.00 feet;  
THENCE South 20°55'55" West for a distance of 145.00 feet;  
THENCE South 02°16'58" West for a distance of 185.00 feet;  
THENCE South 03°37'29" East for a distance of 185.00 feet;  
THENCE South 11°54'18" East for a distance of 275.00 feet;  
THENCE South 21°21'16" East for a distance of 250.00 feet;  
THENCE South 37°17'42" East for a distance of 235.00 feet;  
THENCE South 29°24'31" East for a distance of 120.00 feet;  
THENCE South 17°26'48" East for a distance of 360.00 feet;  
THENCE South 13°34'48" East for a distance of 638.00 feet;  
THENCE South 15°47'30" East for a distance of 285.00 feet;  
THENCE South 27°43'29" East for a distance of 250.00 feet;  
THENCE South 46°31'56" East for a distance of 242.00 feet;  
THENCE South 59°04'59" East for a distance of 224.00 feet;  
THENCE South 65°23'59" East for a distance of 260.00 feet;  
THENCE South 50°46'45" East for a distance of 250.00 feet;  
THENCE South 63°23'06" East for a distance of 262.00 feet;  
THENCE South 84°50'49" East for a distance of 155.00 feet to the northwest boundary of tract referred to as "Outlot 12";  
THENCE North 49°30'25" East along the northwest boundary of said "Outlot 12" for a distance of 831.46 feet to the east line of the NE 1/4 of the SW 1/4 of said Section 16;  
THENCE North 00°25'02" West along the east line of the NE 1/4 of the SW 1/4 of said Section 16 for a distance of 588.87 feet to the POINT OF BEGINNING;  
Containing 169.12 acres more or less. Subject to all easements, restrictions and right-of-way both visible and of record.  
(The basis of bearings for said description are based on the Kansas Regional Coordinate System Zone-07.)

**TRACT 2 DESCRIPTION:**

A tract of land in the Southwest Quarter (SW 1/4) and the West Half of the Northwest Quarter (W 1/2 of the NW 1/4) of Section 16, and in the Southwest Quarter of the Southwest Quarter (SW 1/4 of the SW 1/4) of Section 9, all in Township 1 South, Range 4 East, of the 6th P.M., in Washington County, Kansas, prepared by Clint J. Friedrichs, PLS #1709 on June 21, 2023, being more particularly described as follows:  
BEGINNING at the Southwest (SW) corner of said Section 16;  
THENCE North 00°36'57" West along the west line of the SW 1/4 of the SW 1/4 of said Section 16 for a distance of 1314.40 feet to the Northwest (NW) corner of the SW 1/4 of the SW 1/4 of said Section 16;  
THENCE North 00°03'38" West along the west line of the NW 1/4 of the SW 1/4 of said Section 16 for a distance of 1314.40 feet to the NW corner of the SW 1/4 of said Section 16;  
THENCE North 00°24'51" West along the west line of the NW 1/4 of said Section 16 for a distance of 2628.78 feet to the Northwest (NW) corner of said Section 16, also being the SW corner of said Section 9;  
THENCE North 00°22'32" West along the west line of the SW 1/4 of the SW 1/4 of said Section 9 for a distance of 1242.00 feet to the centerline of the Little Blue River;  
THENCE along the centerline of said Little Blue River for the following twenty four (24) courses:  
THENCE South 66°33'13" East for a distance of 465.00 feet;  
THENCE South 47°26'31" East for a distance of 200.00 feet;  
THENCE South 25°20'26" East for a distance of 500.00 feet;  
THENCE South 11°08'57" West for a distance of 112.00 feet;  
THENCE South 49°04'31" West for a distance of 160.00 feet;  
THENCE South 37°11'31" West for a distance of 450.00 feet;  
THENCE South 46°37'52" West for a distance of 378.00 feet;  
THENCE South 20°55'55" West for a distance of 145.00 feet;  
THENCE South 02°16'58" West for a distance of 185.00 feet;  
THENCE South 03°37'29" East for a distance of 185.00 feet;  
THENCE South 11°54'18" East for a distance of 275.00 feet;  
THENCE South 21°21'16" East for a distance of 250.00 feet;  
THENCE South 37°17'42" East for a distance of 235.00 feet;  
THENCE South 29°24'31" East for a distance of 120.00 feet;  
THENCE South 17°26'48" East for a distance of 360.00 feet;  
THENCE South 13°34'48" East for a distance of 638.00 feet;  
THENCE South 15°47'30" East for a distance of 285.00 feet;  
THENCE South 27°43'29" East for a distance of 250.00 feet;  
THENCE South 46°31'56" East for a distance of 242.00 feet;  
THENCE South 59°04'59" East for a distance of 224.00 feet;  
THENCE South 65°23'59" East for a distance of 260.00 feet;  
THENCE South 50°46'45" East for a distance of 250.00 feet;  
THENCE South 63°23'06" East for a distance of 262.00 feet;  
THENCE South 84°50'49" East for a distance of 155.00 feet to the northwest boundary of tract referred to as "Outlot 12";  
THENCE South 49°30'25" West along the northwest boundary of said "Outlot 12" for a distance of 268.00 feet to the south line of the Northeast Quarter (NE 1/4) of the SW 1/4 of said Section 16;  
THENCE North 89°10'50" West along the south line of the NE 1/4 of the SW 1/4 of said Section 16 for a distance of 458.60 feet to the southwest corner of the NE 1/4 of the SW 1/4 of said Section 16;  
THENCE South 00°31'03" West along the east line of the SW 1/4 of the SW 1/4 of said Section 16 for a distance of 1311.96 feet to the Southeast (SE) corner of the SW 1/4 of the SW 1/4 of said Section 16;  
THENCE North 89°04'00" West along the south line of the SW 1/4 of said Section 16 for a distance of 1321.57 feet to the POINT OF BEGINNING;  
Containing 109.26 acres more or less. Subject to all easements, restrictions and right-of-way both visible and of record.  
(The basis of bearings for said description are based on the Kansas Regional Coordinate System Zone-07.)

**TRACT 3 DESCRIPTION:**

A tract of land in the Northeast Quarter (NE 1/4) of Section 8, Township 1 South, Range 4 East, of the 6th P.M., in Washington County, Kansas, prepared by Clint J. Friedrichs, PLS #1709 on June 21, 2023, being more particularly described as follows:  
COMMENCING at the Southeast (SE) corner of said NE 1/4;  
THENCE North 89°12'14" West along the south line of said NE 1/4 for a distance of 298.46 feet to the POINT OF BEGINNING, point being on the west Railroad Right-of-Way (R/W);  
THENCE continuing North 89°12'14" West along said south line for a distance of 128.19 feet;  
THENCE North 03°30'05" West for a distance of 173.49 feet to the south R/W line of Hollenberg Avenue;  
THENCE South 89°46'32" East for along said south R/W a distance of 28.76 feet to said west Railroad R/W;  
THENCE South 32°10'47" East along said west Railroad R/W for a distance of 206.57 feet to the POINT OF BEGINNING;  
Containing 0.31 acres more or less. Subject to all easements, restrictions and right-of-way both visible and of record.  
(The basis of bearings for said description are based on the Kansas Regional Coordinate System Zone-07.)

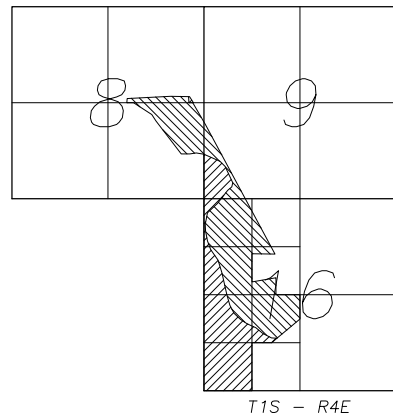

- Notes:
1. Origins of found monuments are unknown unless specified.
  2. Reference ties for Section Corners have been filed with the Kansas State Historical Society.
  3. No Easements, Setbacks and/or Rights-of-Way are certified as part of this report.
  4. Tract boundary is intended to follow the railroad Right-of-Way along a spiral curve in this area. The Right-of-Way is parallel with and 100 feet from the centerline of the railroad.
  5. This Surveyed Tract 3 is owned by the County. It is the surveyors belief that this parcel was intended to be included as part of the transfer that was made through Deed Book 184/ Page 325 but was omitted when generating the description. It is the surveyors opinion that this Tract should be a part of Surveyed Tract 2.

DRAFT

Project#: 233464	PLAT OF SURVEY IN SECTIONS 8, 9, 16, T1S, R4E, OF THE 6th P.M., WASHINGTON COUNTY, KANSAS
Surveyed: cjf/bew/agg	
Detailed: clt	Requested By: Jeff Dankenbring (Agent - Midwest Land & Home)
Reviewed: cjf	
Sheet: 1 of 2	CES GROUP - 605 Broadway, Marysville KS - 785.562.5148 - cesengineering.com

